

TECHNICAL DRAWING / DESSIN TECHNIQUE

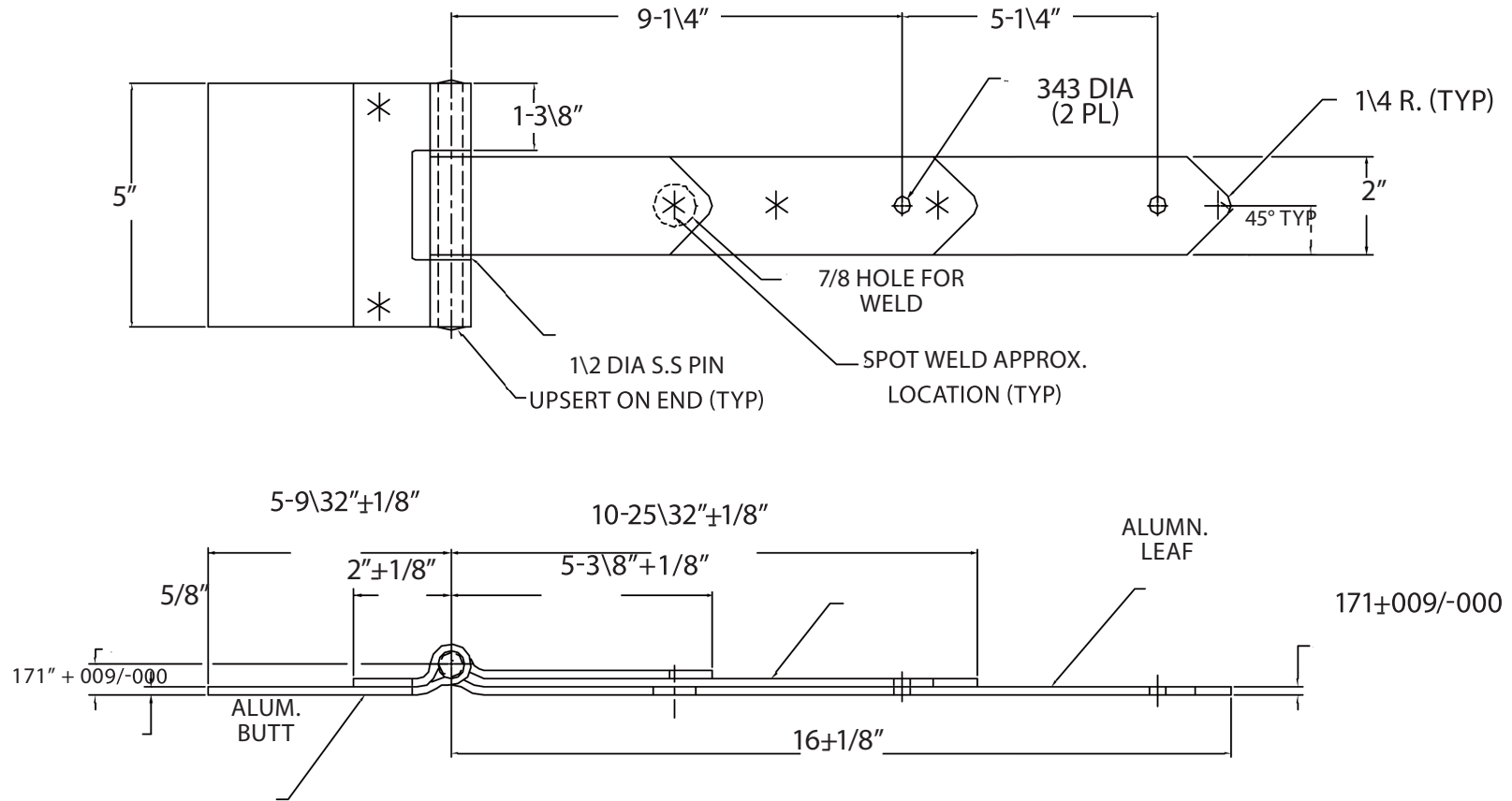

JIMEXS
HARDWARE

1 866 447-5656 / INFO@JIMEXS.COM

WWW.JIMEXS-HARDWARE.COM

204-728

Strap Hinge
 Penture à lame

2021-04-20

PROJECTIONS

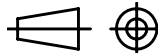

DIMENSIONS
 MATERIAL / MATÉRIEL

16,00" x 5,00"
 Aluminum / Aluminium